



PLANNING COMMITTEE

10.00 AM - TUESDAY, 21 MAY 2024

**MULTI-LOCATION MEETING – COUNCIL CHAMBER PORT TALBOT
AND MICROSOFT TEAMS**

**ALL MOBILE TELEPHONES TO BE SWITCHED TO SILENT FOR THE
DURATION OF THE MEETING**

Webcasting/Hybrid Meetings:

This meeting may be filmed for live or subsequent broadcast via the Council's Internet Site. By participating you are consenting to be filmed and the possible use of those images and sound recordings for webcasting and/or training purposes.

PART 1

1. Chairs Announcements
2. Declarations of Interest
3. Minutes of the Previous Meeting (*Pages 5 - 8*)
4. To Request Site Visit(s) from the Applications Presented

Report/s of the Head of Planning and Public Protection

Section A - Matters for Decision

Planning Applications Recommended for Approval

5. Application No. P2023/0960 - 40 Pentwyn Baglan Road
(*Pages 9 - 26*)
Proposed first floor extension, single storey side extension, single storey outbuilding and retaining wall with driveway extension to

front at 40 Pentwyn Baglan Road, Baglan.

Section B - Matters for Information

6. Appeals Received - 18 March 2024 to 13 May 2024
(Pages 27 - 28)
7. Delegated Decisions - 18 March 2024 to 13 May 2024
(Pages 29 - 48)
8. Urgent Items
Any urgent items at the discretion of the Chairperson pursuant to Section 100BA(6)(b) of the Local Government Act 1972 (as amended).

K.Jones
Chief Executive

Civic Centre
Port Talbot

Wednesday, 15 May 2024

Committee Membership:

Chairperson: Councillor J.Jones

**Vice
Chairperson:** Councillor T.Bowen

Members: Councillors S.Paddison, D.Keogh, R.Davies,
H.Davies, C.James, C.Jordan, S.Thomas,
R.Mizen, P.Rogers and A.R.Aubrey

**Cabinet
UDP/LDP
Member:** Councillor W.F.Griffiths

Requesting to Speak at Planning Committee

The public have a right to attend the meeting and address the Committee in accordance with the [Council's approved procedure](#) which is available at www.npt.gov.uk/planning.

If you would like to speak at Planning Committee on an application reported to this Committee you must:

- Contact Democratic Services in writing at: Civic Centre, Port Talbot SA13 1PJ, preferably by email: democratic.services@npt.gov.uk.
- Ensure your request to speak is made no later than two working days prior to the meeting date (by 2 pm on the preceding Friday based on a usual Tuesday meeting),
- Clearly indicate the item number or application number on which you wish to speak and confirm whether you are supporting or objecting to the application.
- Give your name and address (which will be publicly available unless there are particular reasons for confidentiality)

Please note that only one person is able to speak for each 'category' (objector; supporter; applicant/agent; Town/Community Council for each application. Full details are available in the [Council's approved procedure](#)

In addition, if an objector registers to speak, the Applicant/Agent will be notified by the Council.

Should you wish to discuss any aspect of public speaking, please contact the Democratic Services Team on 01639 763713.

Commenting on planning applications which are to be reported to Committee

Should you wish to submit representations on an application presented to this Planning Committee, please note that these must be received by the Planning department no later than 2.00p.m. on the Friday before Committee (based on the usual Tuesday meeting). If the meeting is not on a Tuesday, these should be received no later than 2.00pm on the penultimate working day immediately preceding the Planning Committee.

Please note that representations received in accordance with the Council's protocol are summarised and, where necessary, commented upon in the form of an Amendment Sheet, which is circulated to Members of the Planning Committee by email on the evening before Committee, and re-distributed prior to the commencement of the meeting.

PLANNING COMMITTEE

(MULTI-LOCATION MEETING – COUNCIL CHAMBER PORT TALBOT
AND MICROSOFT TEAMS)

Members Present:

26 March 2024

Chairperson: Councillor J.Jones

Vice Chairperson: Councillor T.Bowen

Councillors: S.Paddison, R.Davies, H.Davies, C.James,
S.Thomas, R.Mizen, P.Rogers and A.R.Aubrey

UDP/LDP Member: Councillor W.F.Griffiths

Local Members: Councillor M.Crowley (Sandfields East;) and
R.G.Jones (Margam and Taibach;)

Officers In Attendance: C.Morris, C.Davies, G.White, R.MacGregor,
J.Weeks, M.Griffiths, C.Howard, E.O'Brien and
C.Plowman

1. **CHAIRS ANNOUNCEMENTS**

The Chairperson welcomed everyone to the meeting.

2. **DECLARATIONS OF INTEREST**

There were no declarations of interests received.

3. **MINUTES OF THE PREVIOUS MEETING**

The minutes of the meetings held on 12 September 2023 were approved as an accurate record.

4. **TO REQUEST SITE VISIT(S) FROM THE APPLICATIONS PRESENTED**

There were no requests for Site Visit/s received.

5. **APPLICATION NUMBER: P2023/0858 - CROWN WHARF, PORT TALBOT DOCKS**

Officers made a presentation to the Planning Committee on this Application (Demolition of existing structures and erection of a Sustainable Aviation Fuel (SAF) production facility, including the production of green hydrogen and sustainable diesel, enclosed ground flare, storage tanks, installation of pipework and electrical processing and utility equipment, administration, warehouse and laboratory buildings, new access, car parking and transport infrastructure including a truck loading area and associated works, hard and soft landscaping, areas for temporary construction laydown and associated development at Crown Wharf, Port Talbot Docks, Port Talbot, SA13 1RA) as detailed in the circulated report.

The Local Ward Member was present to give their representations at the meeting.

RESOLVED: That in accordance with Officers' recommendations, Application No. P2023/0858 be Approved, subject to the conditions detailed within the circulated report and amendment sheet.

6. **APPLICATION NUMBER: 2024/0057 - 18 DARWIN ROAD**

Officers made a presentation to the Planning Committee on this Application (Attached garage at 18 Darwin Road, Sandfields, Port Talbot, SA12 6BS) as detailed in the circulated report.

RESOLVED: That in accordance with Officers' recommendations, Application No. P2024/0057 be Approved, subject to the conditions detailed within the circulated report and amendment sheet.

7. **APPEALS DETERMINED - 4 SEPTEMBER 2023 TO 18 MARCH 2024**

Members noted the list of Appeals Determined from 4 September 2023 to 18 March 2024.

RESOLVED: That the report be noted.

8. **APPEALS RECEIVED - 4 SEPTEMBER 2023 TO 18 MARCH 2024**

Members noted the list of Appeals Received from 4 September 2023 to 18 March 2024.

RESOLVED: That the report be noted.

9. **DELEGATED DECISIONS - 11 AUGUST 2023 TO 18 MARCH 2024**

Members noted the list of Delegated Decisions from 11 August 2023 to 18 March 2024.

RESOLVED: That the report be noted.

10. **URGENT ITEMS**

There were no urgent items received.

11. **ACCESS TO MEETINGS - EXCLUSION OF THE PUBLIC**

RESOLVED:

That pursuant to Section 100A(4) and (5) of the Local Government Act 1972, the public be excluded for the following item of business which involves the likely disclosure of exempt information as defined in Paragraph 16 of Part 4 of Schedule 12A of the above Act.

12. **TEMPORARY ACCOMMODATION (REGULATORY POSITION)
(EXEMPT UNDER PARAGRAPH 16)**

Members were advised on the agreed regulatory position in relation to temporary accommodation.

RESOLVED: That the report be noted.

CHAIRPERSON

This page is intentionally left blank

SECTION A – MATTERS FOR DECISION

Planning Applications Recommended For Approval

APPLICATION NO: P2023/0960	DATE: 11-01-2024
PROPOSAL: Proposed first floor extension, single storey side extension, single storey outbuilding and retaining wall with driveway extension to front.	
LOCATION:	40 Pentwyn Baglan Road
APPLICANT:	Mr Anthony Veysey
TYPE:	Householder
WARD:	Balgan

BACKGROUND

This application is reported to Planning Committee as Cllr Susanne Renkes requested on the 28th February that this application be determined at Planning Committee due to concerns of overshadowing and overbearing.

SITE AND CONTEXT

The application site is 40 Pentwyn Baglan Road which comprises a detached bungalow located on an elevated plot above the A48 (Pentwyn Baglan Road).

The property is located within a fairly large plot with a garage located to the front of the property at a lower ground level, with front garden. The property also benefits from a large rear garden with a slightly sloping ground level.



The application site is located within settlement limits, with residential properties located to the north, east, south and west of the site. Planning permission has

recently been granted for the construction of a funeral car garage to the southeast of the site with a new access point onto the A48.



DESCRIPTION OF DEVELOPMENT

The application proposes the construction of a first floor extension to the property to convert the dwelling into a two-storey house, plus extensions. The application also proposes a single storey outbuilding to the rear of the site as well as the demolition of the existing garage and construction of new retaining wall and 2 parking spaces to the front.

The proposed first floor extension would increase the eaves and ridge height of the property in order to facilitate the creation of the first floor. The existing property measures 3m to the eaves and 6.1m to the ridge. The proposed eaves height of the property would be 5.1m and the proposed ridge would be 7.6m. This would result in an increase of 2.1m at the eaves and 1.5m at the ridge.

The existing rear extension would also be increased in height to match the proposed eaves at 6.1m and 6.8m to the ridge with an increase in width from 4.2m to 6.3m.

The proposed side extension, located to the south eastern side of the property, would be single storey in form and would measure 11m in depth, 2.7m in width and to a height of 2.7m and 3.4m to the roof light. A pitched roof porch is proposed to the front elevation which would measure 1.8m depth, 2.9m in width and to a height of 2.5m to the eaves and 3.9m to the ridge.

In addition the application proposes a single storey outbuilding to the rear of the garden which would measure 8.8m in width, 4.6m in depth and to a height of 2.4m to the eaves and 3.9m to the ridge. The outbuilding would also include a change in levels at the rear of the garage to provide a levelled surface. This would result in an

increase of 450mm in ground levels to the northwest boundary and a reduction of 280mm to the northeast boundary.

The proposal incorporates the demolition of the existing garage to the front of the site, together with the partial removal of the retaining wall and front garden ground levels. A new retaining wall is proposed to the front elevation with the creation of two parking spaces and the erection of a balustrade.

NEGOTIATIONS

Front garden balustrade set back and reduction of retaining wall.

PLANNING HISTORY

The application site has no relevant planning history.

CONSULTATIONS

Contaminated Land – No objection with request of condition.

Highways - Concerns raised in regard to intensification of access.

Drainage – SAB approval required.

Biodiversity - no objection with request for condition.

Structures – no comment on front masonry wall as designed and main property review at building control stage.

Ward Members were notified and a response was received from Cllr Renkes who raised concerns regarding the proposal and has requested that the application is determined at planning committee.

REPRESENTATIONS

The neighbouring properties were consulted on 16.01.24 and 22.04.24 and a site notice was also displayed on 17.01.24 and 22.04.24.

In response, to date 3no. representations have been received, with the issues raised summarised as follows: -

- Loss of natural light from garden and property and loss of view.
- Increase in height of the proposed extension from existing property not clear from the plans.
- Proposal out of keeping with rest of street.
- Concerns about 'man cave' and possible business use.
- Height of dwelling is out of character and will block natural light to surrounding property.
- Overshadowing regarding the southeast window which would be obstructed.

- Reference to BRE209 and the twenty year rule and the 45 degree rule which would be greatly exceeded by the extra storey, even passing the 65 degree calculation.
- loss of privacy as design would leave one main of access to the rear of no.40, resulting in people standing within 2ft of main window at any time of day and night.
- Application site on elevated ground level and distinctly noticeable at wall plate heights.
- Would cover living room, conservatory, patio and garden by its shadow from sunrise and impact day to day living.
- Overshadowing of rear windows which only receive light for short period during the morning.
- No40 has been built to now impede light to property and required guidelines and further increase in dimensions would do so.
- Overbearing, unpleasant and out of place development.

REPORT

National Planning Policy:

Future Wales: The National Plan 2040 is the national development framework, setting the direction for development in Wales to 2040. The development plan sets out a strategy for addressing key national priorities through the planning system, including sustaining and developing a vibrant economy, achieving decarbonisation and climate resilience, developing strong ecosystems and improving the health and wellbeing of our communities.

The following policies are of particular relevance to the assessment of this application:

Policy 2 – Shaping Urban Growth and Regeneration – Strategic Placemaking

Planning Policy Wales (Edition 12, February 2024)

The primary objective of PPW is to ensure that the planning system contributes towards the delivery of sustainable development and improves the social, economic, environmental and cultural well-being of Wales, as required by the Planning (Wales) Act 2015, the Well-being of Future Generations (Wales) Act 2015 and other key legislation and resultant duties such as the Socio-economic Duty. A well-functioning planning system is fundamental for sustainable development and achieving sustainable places

PPW promotes action at all levels of the planning process which is conducive to maximising its contribution to the well-being of Wales and its communities. It encourages a wider, sustainable and problem solving outlook which focuses on integrating and addressing multiple issues rather than on an approach which is fragmented, un-coordinated and deals with issues in isolation. It provides an opportunity to remove any actual or perceived problems in current approaches and stimulate and support innovative and creative ideas as well as high standards of evidence and assessment to underpin the preparation of development plans and strategies and individual proposals. Monitoring and learning from development outcomes so as to drive sustainable improvements in planning practice is also important.

PPW12 is supported by a series of more detailed Technical Advice Notes (TANs), of which the following are of relevance: -

- Technical Advice Note (TAN) 12: Design (2016)
- Technical Advice Note (TAN) 18: Transport (2007)
Paragraph 2.5 states that “Good design is not inevitable. It requires a collaborative, creative, inclusive, process of problem solving and innovation – embracing sustainability, architecture, place making, public realm, landscape, and infrastructure.”

Local Planning Policies

The Local Development Plan for the area comprises the Neath Port Talbot Local Development Plan which was adopted in January 2016, and within which the following policies are of relevance:

- **Policy BE1** Design
- **Policy TR2** Design and Access of New Development
- **Policy EN6** Important Biodiversity and Geodiversity Sites
- **Policy EN7** Important Natural Features

Supplementary Planning Guidance:

The following SPG is of relevance to this application: -

- Parking Standards (October 2016)
- Design (July 2017)

Issues

Having regard to the above, the main issues to consider in this application relate to the impact on the visual amenity of the area, the amenities of neighbouring residents and highway safety.

Impact on Visual Amenity

The application site is located within settlement limits where by Policy SC1 states that *‘Development within settlement limits that is proportionate in scale and form to the role and function of the settlement as set out in the Settlement Hierarchy will be acceptable in principle’*

The core place making and good design principles of Planning Policy Wales are embodied within Policy BE1 of the Local Development Plan which states that all development proposals will be expected to demonstrate high quality design which fully takes into account the natural, historic and built environmental context and contributes to the creation of attractive, sustainable places and where it is evident that the relevant criteria set out within the policy can be satisfied, this includes but is not limited to the following:

- *It complements and enhances the character and appearance of the site, building or area in terms of siting, appearance, scale, height, massing and elevation treatment;*

- It respects the context of the site and its place within the local landscape, including its impact on the important arterial gateways into the County Borough, its effects on townscape and the local historic and cultural heritage and it takes account of the site topography and prominent skylines or ridges;
- It utilises materials appropriate to its surroundings and incorporates hard and soft landscaping and screening where appropriate;
- It would not have a significant adverse impact on highway safety, the amenity of occupiers of adjacent land or the community;
- It achieves and creates attractive, safe places and public spaces, taking account of 'Secured by Design' principles (including where appropriate natural surveillance, visibility, well lit environments and areas of public movement);

Having regard to the guidance in PPW (4.2.1), which emphasises the need for Councils to “make informed development management decisions that focus on the creation and enhancement of Sustainable Places”, it is considered that Planning has an important role in ensuring not only that new development creates places, and communities, but also that existing communities are protected and enhanced, and that cohesive communities are retained.

The existing street-scene is relatively mixed, with a fairly established building line to the west of the application site. The properties to the west of the site are predominantly two storey in form, however No.42 and 40 are single storey in form and located on elevated plots. Both of these properties again differ in design, with No.42 being split level, with a garage located beneath the main living accommodation, and benefiting from a steeply sloping ridged roof, the ridge of which runs perpendicular with the highway fronting the site, dissimilar to the wider street pattern. The street-scene does gradually slope in gradient from east to west, resulting in the application site located at the higher ground level than the neighbour at no.42. Due to the elevated plot of the application site, the property is widely visible within the street-scene.

Given the mixed street-scene and the sloping gradient the principle of a two storey dwelling is not considered to be unacceptable. The overall development would entail a number of works to the dwelling which would alter the external appearance, massing and scale of the property. The following assessment will evaluate the acceptability of each individual aspect of the development against the relevant planning policies and guidance, before considering the cumulative impact of the development as a whole.

The proposed creation of a first floor would increase the eaves height of the property from 3m to 5.1m resulting in an increase of 2.1m. The proposed ridge height would also be increased from 6.1m to 7.6m, resulting in an increase of 1.5m.

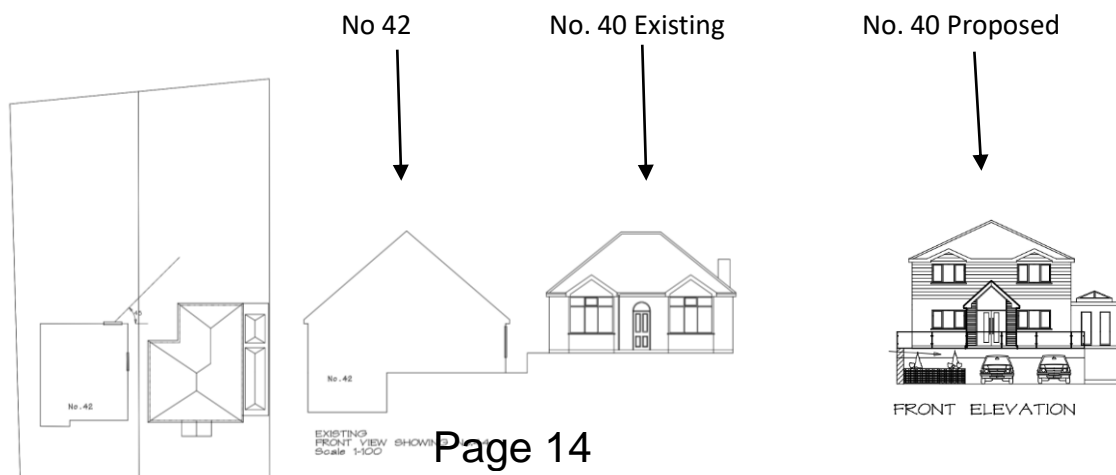

The property would retain the hipped roof form of the existing property however the proposed increase in the height of the dwelling, together with the increase in the rear extension would increase the scale, form and massing of the property when viewed from Pentwyn Baglan Road. As noted above the site is located along the A48, which is characterised by a mix of dwelling scales, forms and designs, and as such this is no uniform scale or design to the dwellings with the immediate locality. While the proposed alterations and extension would alter the character and appearance of the property within the street-scene, given the context of the street-scene the proposal is not considered to result in a detrimental impact in terms of visual impact.

The application site is located on a large plot, set above and back from the road level. It is considered the given the size of the plot the proposed development of this scale and be facilitated on site and is not considered to be an over development of the plot.

The application property is a single storey bungalow and is not considered to attain any distinctive or unique features that would warrant protection in this case. The design of the proposal is considered to be modern with a porch to the front elevation and cladding to the first floor front elevation. Due to the visibility of the property along the A48, a condition will be recommended to ensure material samples are submitted prior to their use of site. The design of the proposal is considered to be fairly traditional with the retention of the hipped roof form and is not considered to result in an incongruous feature within the street-scene and would not be out of keeping with the locality to a degree that would warrant a refusal on the application. Noting that the properties along the wider frontage differ in design that the 2 bungalows that are siting along this forntage.

The proposed single storey side elevation, located to the south east of the property would result in the removal of the existing outbuilding. The extension would be set back from the front elevation by 640mm and would partially visible from the road due to the properties elevated position. However would be of a width and height that is not considered to unacceptably detriment the character and appearance of the dwelling.

The proposed outbuilding would be located to the rear of the site and would not be visible from the road. Due to the sloping gradient of the existing garden, the application proposed works to level the rear section of the garden by increasing the ground level by 450mm to the northwest boundary and a reduction of 280mm to the northeast boundary. The proposed works are considered to be of an appropriate and modest scale. The proposed outbuilding would be set off the boundary with the neighbouring properties and is considered to be of an appropriate form and scale.

The proposed parking area would result in the demolition of the existing garage and the partial removal of the existing garden wall. The proposed retaining wall, planter and parking spaces would alter the appearance of the frontage when viewed from the A48. The proposed parking area would result in the removal of the grassed area to the front of the site however it is considered to be of a scale and design that is common in residential settings and within the street-scene, in order to facilitate off-street parking. Following the submission of amended plans, the balustrade has been set back from the top of the retaining wall, with the wall height reduced from 1.95 to 1.5m. The reduction in wall height and the setback location of the balustrade is considered to reduce the level of engineering work on site which will also retain the

existing sloping site level between the road and property, overall resulting in a more sympathetic design and frontage to the property.

In conclusion, while it is noted that the proposed extension would increase the scale and massing of the property, given the size of the application plot together with the mixed street-scene the proposal is not considered to be of a scale that would unacceptably detriment the character and appearance of the street-scene and property to a degree that would warrant a refusal on the application.

Impact on Residential Amenity

Policy BE1 of the Neath Port Talbot Local Development Plan, states development proposals will only be permitted where it is evident that the criteria set out within the policy can be satisfied, one of which requires development proposals be designed in such a way to ensure 'it would not have a significant adverse impact on highway safety, the amenity of occupiers of adjacent land or the community'.

The application site is located within a residential street-scene with properties located to the north, east and west. No42 Pentwyn Baglan Road is located to the north west of the application site, and is located on a lower ground level. It is noted that there is a ground floor side elevation window at no.42 facing the application site. Due to the change in levels the window is partially located below the ground level of the application site and is set off the boundary by approximately 900mm.

It is noted that concerns were initially raised with regard with the impact upon the side elevation window. Following a site visit to No.42 it was found that the side elevation window within the living room area is a secondary window with a further window located on the rear elevation. Furthermore, due to the change in levels between the application site and No.42, the existing outlook from the side elevation is to the existing retaining boundary wall and the existing side elevation of the application property.

As such, while it is noted that the proposals will increase the eaves level and height of the application property, it is not considered to change or unacceptably detriment the outlook from the side elevation window, and the changes would be above the window and eaves level of the property, no nearer to the window. It is noted that side elevation windows on properties generally receive less light, and in this case, due to the proximity of the window to the boundary the window partially relies on light from the side elevation of the application site, which cannot be secured as it is outside of the neighbour's ownership and/or control. It is noted that the applicant could install a 2m boundary treatment under permitted development which would be closer to the window than the existing dwelling.

In light of the above factors, including the existing window outlook, the fact that this is a secondary window on the side elevation and the applicant's ability to install a 2m fencing on the boundary, the proposal is not considered unacceptably impact upon the residential amenity the neighbouring property, in terms of the impact upon the side elevation window.

With regard to the overall scale and massing of the proposed works, the proposed rear extension would be brought 2m closer to the boundary with No. 42 and would be set off the boundary by 4m. due to the orientation of the sun the proposal would result in a partial reduction in day light during the morning, however due to the siting of the two properties alongside each other and the design of the rear extension, set off the boundary the proposal is not considered to result in a level of

overshadowing that would be uncharacteristic of a residential property and would unacceptably detriment the residential amenity of the neighbouring property.

The design and siting of the proposed rear extension ensures that the rear extension aspect of the development complies with the 45 degree rule as defined within the Householder Design Guide. While it is noted that the 45 degree rule is generally used for first floor windows, given the context of the site it has been included within the assessment. This rule requires that two-storey extensions are sited to ensure that they do not cross a 45 degree line which is drawn from the mid-point of the nearest habitable room window on the neighbouring property.

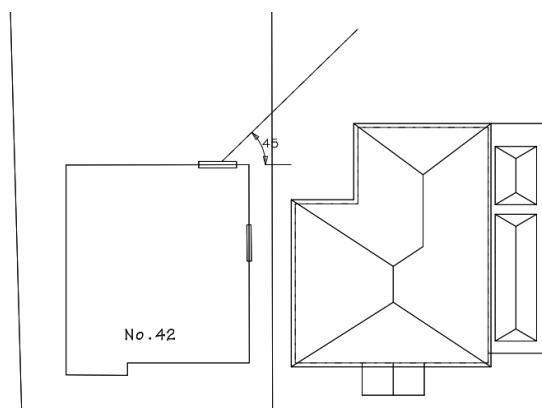

The proposed first floor extension would result in windows to the rear elevation of the property at first floor. While it is noted that angled first floor rear elevation views are common between residential properties the installation of a new window opening next to the boundary with No. 42 is considered to result in new views towards the garden area. It is noted that the floor plans illustrate that the closest window to the neighbouring property at No. 42 would be for a bathroom and as such a condition will be attached to any permission granted to ensure the window is installed and retained with obscure glazing. It is noted that two further rear elevation windows are proposed within the rear extension. Due to the depth of the extension and its off-set from the boundary, the views from the windows are considered to be acute and are not considered to result in a degree of overlooking that would unacceptably impact the privacy or residential amenity of the neighbouring property.

The proposed single storey side extension would be screened from view by the neighbouring property at No. 42 as it is located on the opposite side of the dwelling. It is noted that concerns have been raised by the location of the side extension as it would result in only one rear external access point for the application site and subsequently result in increased comings and goings to the northern side of the site. It is noted that the external access is existing on site and as such is not considered to unacceptably impact upon the privacy of the neighbouring property.

The proposed outbuilding would be sited at the bottom of the garden and would be set off the boundary with the neighbouring property at no.42 by 2.5m. It is noted that the ground levels next to the boundary would be increase by a maximum of 450mm for approximately 7.9m however the increase is not considered to be of a scale that would unacceptably impact upon the residential amenity of the neighbour.

The proposed outbuilding would be set off the boundary with a hipped roof design and while it would be visible from the rear of No.42 it is considered to be of a scale

and design that would not result in an overbearing or overshadowing impact upon the neighbour.

The proposed parking area to the front of the application site, would result in the construction of a 1.5m retaining wall and the removal of the existing garage and grass area. Following the submission of amended plans the retaining wall height has been reduced and the balustrade has been set back from the property with an increase in ground levels to the front of the property at 300mm.

The proposed retaining wall and parking area is considered to be of a modest scale, which would reduce the ground levels at the front of the site and is not considered to unacceptably impact upon the residential amenity of the neighbours at No.42.

With regard to the neighbouring properties to the rear of the application site along St Catherines Road, and shares a boundary with no.22, 24 and 26. The property is set off the boundary with the neighbouring properties by approximately 20.7m and is in excess of 30m from the rear elevations of the properties.

The proposed first floor extension and rear extension would increase the massing of the property when viewed from the rear of the properties along St Catherines Road, however due to the distance of the application property from the boundary with the neighbours the proposal is not considered to result in an overbearing impact upon the dwellings.

In line with the Design SPG Householder Design Guide a distance of 21m is expected between habitable room windows. The introduction of first floor windows to the rear elevation of the application site would result in views towards the rear of properties along St. Catherines Road, however as the distances would exceed 10.5m to the garden areas and exceed 21m to the rear elevations of the dwellings, the proposal is not considered to unacceptably impact upon the residential amenity and privacy of the neighbouring properties.

The proposed outbuilding to the rear of the application site would be set off the boundary with the neighbouring properties by a minimum of 2m. It is noted that outbuildings can be constructed under permitted development up to 4m in ridge height and 2.5m eaves height which the proposed outbuilding would be within. However due to the change in levels to provide a levelled area for the outbuilding, the eaves and ridge height would exceed the Permitted Development allowance by 100mm at the eaves and 150mm at the ridge. While it is noted that concerns have been raised regarding the proposed outbuilding, consideration is given to its off-set from the boundary and its minor scale above the permitted development criteria. As such while the outbuilding would be partially visible from the rear of no.22-26 Catherines Road it is not considered to be of a scale or massing that would unacceptably impact upon the residential amenity of the neighbour.

With regard to the neighbouring property at No. 38 Pentwyn Baglan Road, it is noted that the property is set off the boundary with the application site by 30m. It is noted that planning permission has been granted for the construction of a new access point and funeral car garage on the garden area to the north west of No.38, however work has not yet commenced. The proposed side elevation first floor window would be located in fairly close proximity to the boundary and would have uninterrupted views to the south east and into the garden of No. 38, and as such a condition will be attached to the decision notice to ensure the en-suite window is fitted and retained with obscure glazing.

It is noted that the single storey extension is located in close proximity to the boundary however is considered to be of a modest scale that is not considered to unacceptably impact upon the residential amenity of No. 38. In addition the proposed first floor extension and rear extension would increase the massing of the property, however due to the distance of the application property from No.38 is it not considered to result in an overbearing or overshadowing impact that would unacceptably impact upon the residential amenity of the neighbour.

The neighbouring properties opposite the application site, along Rhodfa Pentwyn would be in excess of 30m from the application site and separated by the A48. As such the proposal is not considered to unacceptably impact upon the residential amenity of the properties.

Taking the above into account, it is not considered that the development will adversely affect the residential amenity of any of the surrounding properties. It is therefore considered that the proposal would comply with Policy BE1 of the Local Development Plan.

Parking and Access Requirements and Impact on Highway Safety

Policy TR2 of the Local Development Plan states that permission will be granted for development that is acceptable in terms of access, parking and highway safety.

The Head of Highways and Engineering were consulted as part of the application and provided the following the response, noting that concerns were raised;

The proposed parking would intensify the use of this substandard access point. The existing access could only accommodate 1 vehicle whereas the proposed arrangement allows for 2 vehicles to be parked side by side. This would intensify the use of a substandard access with limited vehicular visibility, increasing the likelihood of conflict between vehicles at this location. This location is a busy A-Classified road (and bus route), with no footway buffer between the access point and carriageway.

As previously suggested, there appears to be scope to provide a turning facility within the frontage of the property. If a satisfactory turning facility is provided, Highways would look more favourably on allowing the intensification of this access point as the turning facility would provide a betterment to the safety of the access.

The application site currently benefits from one off road parking space in the single garage, with a substandard driveway. The existing garage measures 3.45m in width and 6.2m in depth externally and the driveway measuring approximately 4.2m in depth and 3.9m in width. It is noted that the expected internal dimensions for a single garage within the Parking Standards SPG is 6m x 3m.



It is noted that Highways have raised concerns with the intensification of the access to provide two off-road parking spaces in replacement of the existing garage and substandard driveway, with the suggestion of providing a turning area on site. However it is noted that the parking spaces would be located towards the eastern side of the site, where the existing access point was, with the partial removal of the front retaining wall. The proposed planter and removal of the retaining wall is considered to increase visibility to the west, with the parking spaces set off the boundary retaining wall by 3.65m.

The proposed parking spaces would measure 8.7m in depth and 3.45m in width which is above the Parking Standards SPG guidance of 2.6m x 4.8m.

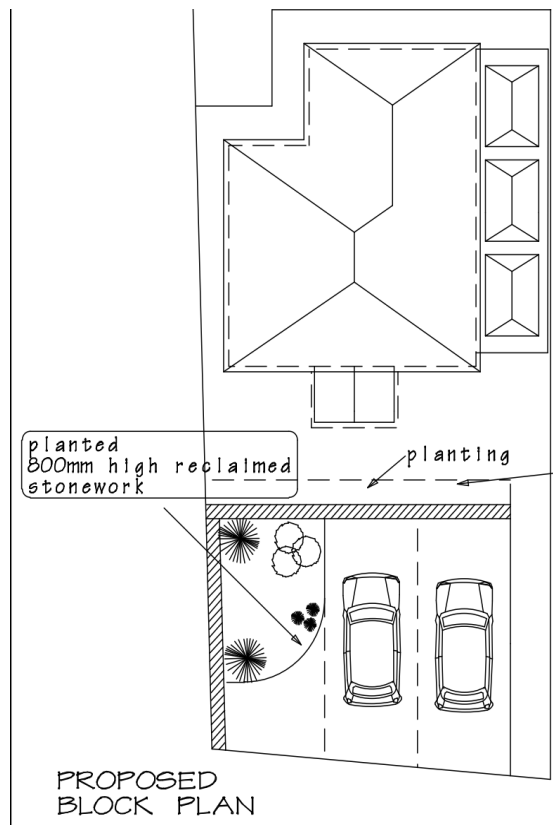

It is also noted that the access onto the Classified road (A48) is existing, with numerous properties along this section of Pentwyn Baglan Road having direct access without a turning area. As such, while regard is given to the response received from the Highway Section, the proposal would result in two adequate parking spaces, with the removal of the retaining wall next to the highway, within an existing access, and therefore it is not considered reasonable to refuse the application on highway and pedestrian safety grounds in this case.

A condition will be added to any permission issued to ensure that the parking area is completed, retained and bound and porous material.

Biodiversity

As identified above, Policies EN6 and EN7 of the Local Development Plan will be of relevance insofar as there is a need to ensure any impacts on biodiversity/ natural features are appropriately assessed and, where applicable, mitigated.

Planning Policy Wales (PPW) 12 sets out that;

The quality of the built environment should be enhanced by integrating green infrastructure into development through appropriate site selection and use of creative design. With careful planning and design, informed by an appropriate level of assessment, green infrastructure can embed the benefits of biodiversity and ecosystem services into new development and places, help to overcome the potential for conflicting objectives, and contribute to health and well-being outcomes.

A green infrastructure statement should be submitted with all planning applications. This will be proportionate to the scale and nature of the development proposed and will describe how green infrastructure has been incorporated into the proposal. In the case of minor development this will be a short description and should not be an onerous requirement for applicants. The green infrastructure statement will be an effective way of demonstrating positive multi-functional outcomes which are appropriate to the site in question and must be used for demonstrating how the step-wise approach (Paragraph 6.4.15 of PPW 12) has been applied.

A Green Infrastructure statement has been submitted as part of the application which states that there are two trees to the rear of the garden with hedgerow on site. A section of lawn would be removed in order to construct the retaining wall and parking area. From undertaking a site visit the two leylandi trees located to the bottom of the garden are located within the neighbours property. Due to the offset of the outbuilding from the boundary it is not considered to unacceptably impact upon the trees. The Green Infrastructure Statement proposes the installation of a bird box to the rear elevation of the extension, which would be secured by a suitably worded condition.

Other Matters

As identified earlier in this report, representations were received in response following the publicity exercise. In response to the issues raised which have not been addressed elsewhere in this report, the following comments are made:

- Loss of view is not a planning matter and loss of light towards neighbouring properties has been considered above. However, the orientation of the properties does not result in any significant loss of view to the front or rear.
- Increase in height of the proposed extension from existing property not clear from the plans – the proposed plans are to scale and the measurements of the extension are included above.
- Concerns about ‘man cave’ and possible business use, and can you confirm limited use. – the proposed outbuilding would be located to the rear of the property and does not lend itself for a commercial use. Should the applicants wish to use the unit for another purpose than ancillary to their dwelling planning permission would be required.
- Reference to BRE209 and the twenty year rule and the 45 degree rule which would be greatly exceeded by the extra storey, even passing the 65 degree calculation - the impact on the side elevation window at no42 has been assessed above, the BRE209 is not planning policy.

CONCLUSION

The decision to recommend planning permission has been taken in accordance with Section 38 of The Planning and Compulsory Purchase Act 2004, which requires that, in determining a planning application the determination must be in accordance with the Development Plan unless material considerations indicate otherwise. The Development Plan comprises Future Wales - the National Plan 2040 and the Neath Port Talbot Local Development Plan (2011–2026) adopted January 2016.

It is considered that the proposal represents an appropriate form of development that would have no unacceptable impact on the amenities of neighbouring residents, visual amenity of the area, biodiversity or highway and pedestrian safety. Accordingly, the proposed development is in accordance with Policies BE1 (Design) and TR2 (Design and Access of New Development) of the Neath Port Talbot Local Development Plan.

It is further considered that the decision complies with Future Wales - the National Plan 2040 and the Council’s well-being objectives and the sustainable development principle in accordance with the requirements of the Well-being of Future Generations (Wales) Act 2015.

RECOMMENDATION

Approval, subject to conditions.

Time Limit Conditions

- 1 The development shall begin no later than five years from the date of this decision.

Reason:

To comply with the requirements of Section 91 of the Town and Country Planning Act 1990.

List of Approved Plans

- 2 The development shall be carried out in accordance with the following approved plans and documents:

Green Infrastructure
Statement 09.01.2024

40-PBR-00 - Location Plan
and Block Plan 2023/08 -
Existing Elevations

2023/08 - Existing Layout and
Block Plan 2023/08 - Proposed
Roof Plan

2021/04 - Proposed man cave

2024/02 - Proposed Elevations January 2024

2023/08 - Proposed Ground Floor and First Floor Layout
November 2023 23-108-01 - Retaining wall section

23-108 Rev 1 Structural calculations

2024/03 - Block plans and sections
April 2024 2023/08 - Existing Block
Plan and front view

Reason:

In the interests of clarity.

Action Conditions

- 3 Notwithstanding the details submitted, prior to the first beneficial use of the first floor extension hereby approved, the first floor northern rear elevation serving the ensuite and the eastern first floor side elevation window serving the ensuite, shall be fitted with obscured glazing, and any part of the window that is less than 1.7m above the floor of the room in which it is installed shall be non-opening. The windows shall be permanently retained as such thereafter,

Reason :

In the interest of the amenities of the adjoining property, and to ensure accordance with Policy BE1 of the adopted Neath Port Talbot Local Development Plan.

- 4 Prior to the first beneficial use of the extensions hereby permitted, an artificial nesting site for birds shall be erected on the dwelling to one of the following specifications, and retained as such thereafter;

Nest Box Specifications for House Sparrow Terrace:

Wooden (or woodcrete) nest box with 3 sub-divisions to support 3 nesting pairs. To be placed under the eaves of building.

Entrance holes: 32mm diameter

Dimensions: H310 x W370
x D185mm or

Swift Nest Box Specification:

Wide box with small slit shaped entrance hole. Must be placed under or close to roof, at least 5m from the ground.

Dimensions: H150 x W340
x D150mm Reason:

In the interest of biodiversity, and to mitigate to loss of bird nesting/foraging habitats under the Habitats Regulations (amended 2012) and to accord with Policy SP15 of the adopted Neath Port Talbot Local Development Plan.

- 5 Prior to the first beneficial use of the extensions hereby approved, the parking area to the front of the site shall be constructed in a hardwearing porous material, such as block paving or asphalt, with measures to ensure no surface water run off into the adopted highway, and retained as such use thereafter.

Reason:

In the in interest of highway and pedestrian safety and to ensure compliance with Policy TR2 of the Neath Port Talbot Local Development Plan.

- 6 Prior to their use in the construction of the development hereby permitted, details and samples of the materials to be used in the construction of the external surfaces of the development shall be submitted to and approved in writing by the Local Planning Authority. Development shall be carried out in accordance with the approved details.

Reason:

In the interest of the visual amenity of the area and to ensure the development complies with Policy BE1 of the Neath Port Talbot Local Development Plan.

Regulatory Conditions

- 7 In the event that contamination is found at any time when carrying out the approved development that was not previously identified, work on site shall cease immediately and shall be reported in writing to the Local Planning Authority. A Desk Study, Site Investigation, Risk Assessment and where necessary a Remediation Strategy must be undertaken in accordance with the following document:- Land Contamination: A Guide for Developers (WLGA, WAG & EAW, July 2006). This document shall be submitted to and agreed in writing with the Local Planning Authority. Prior to occupation of the development, a verification report which demonstrates the effectiveness of the agreed remediation, shall be submitted to and agreed in writing with the Local Planning Authority.

Reason:

To ensure that risks from land contamination to the future users of the land and neighbouring land are minimised, together with those to controlled waters, property and ecological systems, and to ensure that the development can be carried out safely without unacceptable risks to workers, neighbours and other off site receptors, and to ensure compliance with Policies SP16 and EN8 of the Neath Port Talbot Local Development Plan.

- 8 No surface water and/or land drainage shall be allowed to connect directly or indirectly with the public sewerage network including any increase in the roof area of the building /or impermeable surfaces within the curtilage.

Reason:

To prevent hydraulic overloading of the public sewerage system, to protect the health and safety of existing residents and ensure no pollution of or detriment to the environment, and to and ensure the development complies with Policy SP16 and BE1 of the Neath Port Talbot Local Development Plan.

SECTION B – MATTERS FOR INFORMATION

APPEALS RECEIVED

a) Planning Appeals

Appeal Ref: A2024/0006 **Planning Ref:** P2023/0655

PINS Ref: CAS-03238-F0D9F7

Appellant: Mr Roy Harris

Proposal: Section 73 application to remove condition 1 (agricultural occupancy restriction) of planning permissions 2/2/91/0182/01 dated 21 November 1991 and 2/2/92/0471/02 dated 11 December 1992

Site Address: Pant Y Gwanyd Farm Allt Y Grug Farm Road
Link To Carreg Pentwyn Farm Ystalyfera SA9
2BE

Start Date: 8 May 2024

Appeal Method: Written Representations

b) Enforcement Appeals

This page is intentionally left blank

SECTION B – MATTERS FOR INFORMATION

DELEGATED APPLICATIONS

DETERMINED BETWEEN 18 MARCH 2024 AND 13 MAY 2024

App No: **P2020/0756**

Proposal: Retention and completion of engineering works to form tiered garden area together with new fencing to all rear garden boundaries.

(Amended drawings and proposal received 25.02.24 / 08.02.24)

Location: 19 Crymlyn Gardens Skewen SA10 6EU

Decision: Approved

Ward: Coedffranc West

App No: **P2021/1245**

Proposal: Outline application (including access) for one detached rural enterprise dwelling and garage including parking and associated works

(Amended site and location plan received)

Location: Ty'n Y Cwm Farm Ty'n Y Cwm Lane Rhos Pontardawe Swansea

Decision: Approved

Ward: Rhos

App No: **P2022/1093**

Proposal: Demolition of Lonlas Boys Club and nearby garages and construct two pairs of semi-detached dwellings.

Location: Lonlas Boys Club Lonlas Avenue Lonlas Neath Neath Port Talbot

Decision: Approved subject to a 106 agreement

Ward: Coedffranc North

App No: **P2023/0135**

Proposal: Details to be agreed in association with condition 5 (ground contamination desk top assessment); condition 6 (remediation scheme); condition 7 (material samples) and condition 8 (refuse and recycling strategy) of application P2021/0856 granted on 22/12/22.

Location: Eagle House 2 Talbot Road Port Talbot Neath Port Talbot SA13 1DH
Decision: Approved
Ward: Port Talbot

App No: **P2023/0633**
Proposal: Outline application for construction for 2 No. detached dwellings with parking and ancillary works (including details of access, layout and scale)

Location: 1 Gelliceibryn Glynneath Neath Neath Port Talbot SA11 5ED
Decision: Refused
Ward: Glynneath Central & East

App No: **P2023/0659**
Proposal: Demolition of existing visitor centre and construction of new 2 storey visitor centre including new balustrades, sprinkler tank, external lighting of pedestrian routes from existing car park and associated landscaping and drainage works

Location: Gnoll Estate Country Park Fairyland Neath SA11 3BS
Decision: Approved
Ward: Neath North

App No: **P2023/0676**
Proposal: Proposed single storey rear extension and change of use of Pond Cottage to form a tea room/cafe (A3 use).

Location: Pond Cottage Gnoll Estate Country Park Fairyland Neath SA11 3BS
Decision: Approved
Ward: Neath North

App No: **P2023/0809**
Proposal: Conversion of existing stables to annex ancillary to host dwelling with extension to surrounding raised platform and balustrade and development of access ramp.

Location: Keepers Lodge Lane From Church Road To Keepers Lodge Cilybebyll Pontardawe SA8 3JS
Decision: Approved
Ward: Rhos

App No: **P2023/0845**
Proposal: Conversion of rear section of existing building to create a shrimp farm (aquaculture business) including reconfiguration and cladding of roof to provide additional height clearance together with ancillary alterations and drainage

Location: The Metal Box Milland Road Industrial Estate Neath Neath Port Talbot SA11 1NJ

Decision: Approved
Ward: Neath East

App No: **P2023/0873**
Proposal: Conversion of chapel and vestry buildings into a single residential dwelling

Location: Ebenezer Independent Chapel Neath Road Rhos Pontardawe SA8 3HB

Decision: Approved
Ward: Rhos

App No: **P2023/0876**
Proposal: Proposed single storey annex situated on the side elevation of host dwelling.

Location: Crachlwyn Farm Gwrhyd Road Pontardawe Swansea Neath Port Talbot

Decision: Approved
Ward: Pontardawe

App No: **P2023/0885**
Proposal: Proposed extensions at roof space and single storey extension to bungalow

Location: 12 Woodlands Terrace Resolven Neath Neath Port Talbot SA11 4NG

Decision: Approved
Ward: Resolven & Tonna

App No: **P2023/0896**
Proposal: Application to discharge conditions 7 (relating to a drainage scheme) 10 (relating to an ecological management and monitoring plan) and 15 (restoration and aftercare scheme) attached to planning permission P2021/1277
Location: Pwllfawatkin Landfill Site Pontardawe Link Road To Baran Road Pontardawe SA8 4RX
Decision: Approved
Ward: PontardawePontardawe

App No: **P2023/0900**
Proposal: Proposed replacement storage shed (B8) - agriculture (non-commercial)
Location: Land Adj Hawkers Cottage King Edward Road Tairgwaith Neath Port Talbot SA18 1YL
Decision: Refused
Ward: Gwaun Cae Gurwen & Lower Brynamman

App No: **P2023/0908**
Proposal: Proposed 2 storey rear extension and rear retaining wall.
Location: 64 Lucy Road Lonlas Skewen SA10 6RR
Decision: Approved
Ward: Coedffranc North

App No: **P2023/0925**
Proposal: Detached outbuilding, raising part of garden to facilitate access to outbuilding, new retaining walls and steps.
Location: 1 Kenilworth Court Baglan Port Talbot Neath Port Talbot SA12 8NN
Decision: Approved
Ward: Baglan

App No: **P2023/0940**
Proposal: Two storey side and rear extension and single storey rear extension

Location: 8 Poplars Avenue Cimla SA11 3NS
Decision: Approved
Ward: Neath South

App No: **P2023/0943**

Proposal: Application to discharge condition 11 (relating to an environmental scheme) attached to planning permission P2022/1040

Location: Cwm Nant Lleci Quarry Gellifowy Road Ynysmeudwy Pontardawe Swansea

Decision: Approved

Ward: Cwmllynfell & Ystalyfera

App No: **P2023/0950**

Proposal: Proposed off-road parking space to front of dwelling, with dropped kerb, railing and ramp.

Location: 29 Emroch Street Goytre Port Talbot Neath Port Talbot SA13 2YE

Decision: Approved

Ward: Margam & Taibach

App No: **P2024/0006**

Proposal: Proposed single storey rear extension

Location: 38 George Street Port Talbot Neath Port Talbot SA13 1ES

Decision: Approved

Ward: Port Talbot

App No: **P2024/0007**

Proposal: Change of Use to 5 bedroom House of Multiple Occupancy (HMO)(use class C4), and demolition of rear outbuilding.

Location: 31 Ynys Street Port Talbot SA13 1YW

Decision: Approved

Ward: Port Talbot

App No: **P2024/0012**

Proposal: First floor extension on existing changing block

Location: Unit 9 Gym Quay Road Neath SA11 1SN
Decision: Approved
Ward: Neath North

App No: **P2024/0027**

Proposal: Change of use from light industrial (Use Class B1) to vehicle repairs (Use Class B2) with ancillary MOT station.

Location: Unit 6 Isaacs Place Aberavon SA12 6NP
Decision: Approved
Ward: Aberavon

App No: **P2024/0031**

Proposal: Single storey rear extension.
Location: 46 Lake Road Sandfields SA12 6AF
Decision: Approved
Ward: Sandfields East

App No: **P2024/0032**

Proposal: Construction of raised platforms and steps including retaining works, means of enclosure and associated landscaping to the rear of the property (works commenced). Plus retrospective consent for construction of detached garage structure.

Location: 8 St Annes Drive Tonna Neath Neath Port Talbot SA11 3JU
Decision: Approved
Ward: Resolven & Tonna

App No: **P2024/0048**

Proposal: Demolish outbuilding and construct single storey wrap around rear extension

Location: 12 Grove Road Pontardawe SA8 4HH
Decision: Approved
Ward: Pontardawe

App No: **P2024/0049**

Proposal: Proposed change of use of upper ground floor from class D1 to class C3 dwelling, with extension to provide a new porch. The lower ground floor would remain unaltered as garages serving Ynysllynlladd House.
Location: The Old Coach House Main Road Cadoxton SA10 8DA
Decision: Approved
Ward: CadoxtonCadoxton

App No: **P2024/0062**
Proposal: Two storey side extension and infill extension to front elevation to create new front entrance
Location: Ty Camlas New Road Clyne SA11 4ET
Decision: Approved
Ward: Resolven & Tonna

App No: **P2024/0067**
Proposal: Side and rear wrap-around dormer to roof, front canopy over front door and bay window and associated works.
Location: 59 Crymlyn Road Skewen Neath Neath Port Talbot SA10 6EG
Decision: Refused
Ward: Coedffranc West

App No: **P2024/0068**
Proposal: Discharge of Condition application for condition 3 (Biodiversity enhancement scheme) of planning application P2023/0729 approved on the plan 03.01.2024.
Location: Seaway Parade Industrial Estate Baglan SA12 7BR
Decision: Approved
Ward: Baglan

App No: **P2024/0074**
Proposal: Change of use of ground floor from hair and beauty salon (use class Sui Generis) to Shop (use class A1)
Location: 139 Pantyrheol Neath Neath Port Talbot SA11 2HB
Decision: Approved
Ward: Neath East

App No: **P2024/0075**
Proposal: Single storey extension to the side and rear of dwelling.
Location: 1 Channel View Bryncoch Neath Neath Port Talbot
SA10 7TH
Decision: Approved
Ward: Bryncoch North

App No: **P2024/0076**
Proposal: Part two storey and part single storey rear extension.
Location: 13 Western Avenue Sandfields Port Talbot Neath
Port Talbot SA12 7LS
Decision: Approved
Ward: Sandfields East

App No: **P2024/0081**
Proposal: Certificate of lawfulness for proposed installation of new cryogenic plant on a piled concrete plinth and the erection of a new nitrogen tank and associated plant including vaporisers, accumulators and pumps sited adjacent to an existing cryogenic plant (to be decommissioned) within an existing area of hardstanding within the curtilage of the existing Wall Colmonoy buildings. The dimensions of the plinth are 17.8m x 11.5m. The total height of the nitrogen tank when mounted on the plinth is 14.93m, the tank is 3m diameter.
Location: Wall Colmonoy Alloy Industrial Estate Pontardawe
SA8 4HL
Decision: Approved
Ward: Pontardawe

App No: **P2024/0083**
Proposal: Construction of all-weather paddock/manege (60m x 40m) including sustainable drainage, wooden post and rail fencing.
Location: Ynysarwed Farm Lane From Neath Road To
Ynysarwed Farm Abergarwed SA11 4DD
Decision: Approved

Ward: Resolven & Tonna

App No: **P2024/0099**

Proposal: Part retrospective outbuilding to be used as a granny annex (amended description).

Location: 58 Southville Road Sandfields Port Talbot Neath Port Talbot SA12 7DS

Decision: Approved

Ward: Sandfields West

App No: **P2024/0101**

Proposal: Single storey front porch extension.

Location: 4 St Davids Road Sandfields SA12 6PP

Decision: Approved

Ward: Sandfields East

App No: **P2024/0102**

Proposal: New off road front vehicular parking area and access

Location: 44 Cimla Road Neath Neath Port Talbot SA11 3TL

Decision: Refused

Ward: Neath North

App No: **P2024/0103**

Proposal: Extended vehicular off road parking

Location: 38 Chestnut Road Cimla SA11 3PB

Decision: Issue Certificate

Ward: Neath South

App No: **P2024/0106**

Proposal: Refurbishment of existing playground at the seafront in Aberavon. The works to which include the erection of a play structure with a maximum height of 8.91m and other associated works.

Location: Aberavon Seafront Playground The Princess Margaret Way Sandfields SA12 6QW

Decision: Approved

Ward: Sandfields West

App No: **P2024/0109**
Proposal: Conversion of ground floor offices to a self-contained residential apartment, together with use of basement for ancillary domestic storage associated with both proposed ground floor apartment and existing first floor residential apartment at No. 94 Commercial Street
Location: 92 Commercial Street Ystalyfera SA9 2HU
Decision: Approved
Ward: Cwmllynfell & Ystalyfera

App No: **P2024/0110**
Proposal: Details to be agreed in association with condition 3 (construction environmental management plan) of P2023/0393 granted on 20/09/2023 (Amended construction environmental management plan received 26.03.24)
Location: Crymlyn Primary School School Road Jersey Marine Neath Neath Port Talbot
Decision: Approved
Ward: Coedffranc West

App No: **P2024/0113**
Proposal: Single storey rear extension.
Location: 28 Vivian Park Drive Sandfields SA12 6RT
Decision: Approved
Ward: Sandfields East

App No: **P2024/0115**
Proposal: Discharge of conditions 7 (gigabit capable infrastructure), 11 (lighting) and 14 (external materials) of planning permission P2023/0499 dated 10.10.2023 (for demolition of existing nursing home and construction of new care facility)
Location: Cardonnel Court Nursing Home Cardonnel Road Skewen SA10 6BS
Decision: Approved
Ward: Coedffranc Central

App No: **P2024/0116**
Proposal: Discharge of Conditions 3 (lighting), 4 (bat/bird boxes), 5 (hedgehog fence), 8 (landscaping management plan), 10 (otters), 17 (external materials), 18 (drainage) and 21 (refuse/recycling collection) of planning permission P2023/0265 dated 22.08.23 (for construction of 15 no. light industrial/commercial units and associated works)
Location: Land To The North Of Old Foundry Road, Pontardawe SA8 4ET
Decision: Approved
Ward: Pontardawe

App No: **P2024/0122**
Proposal: Variation of condition 1 of planning permission P2019/0267 for Detached Garage. Approved on 04/06/19 for the consent to be extended for a further 5 years.
Location: 1 Jubilee Crescent Skewen SA10 6TP
Decision: Approved
Ward: Coedffranc North

App No: **P2024/0126**
Proposal: Details to be agreed in association with conditions 3 (phase 1 contamination risk assessment), 4 (remediation strategy) and 7 (foundation design) of planning permission P2022/0515 dated 16.03.23 (to construct a two-storey side extension and convert existing building to provide 12 no. self-contained flats)
Location: Ty Mawr Ynisderw Road Pontardawe SA8 4EG
Decision: Refused
Ward: Pontardawe

App No: **P2024/0127**
Proposal: Two storey rear extension
Location: 5 Mary Street Blaengwynfi Port Talbot Neath Port Talbot SA13 3TT
Decision: Approved
Ward: Gwynfi & Croeserw

App No: **P2024/0131**
Proposal: Change of use from office for financial advisors A2 to mixed use - financial advisers and beauty treatment rooms (use classes A2/Sui Generis). No structural work required just use of existing empty rooms.
Location: 27 Victoria Gardens Neath SA11 3AY
Decision: Approved
Ward: Neath North

App No: **P2024/0132**
Proposal: Felling of 2 no oak trees (T1 and T2) and 1 no. goat willow tree (G1) and removal of group of boundary trees (G2) consisting of 2 no. oak and 1 no. sycamore (protected by Tree Preservation Order No. T206)
Location: Land Between 77 And 79 Pen Yr Alltwn Alltwn Pontardawe SA8 3EA
Decision: Refused
Ward: RhosRhos

App No: **P2024/0134**
Proposal: Proposed detached garden room, the works for which include the demolition of an existing detached outbuilding and existing stonework rear wall
Location: 3 Connaught Street Port Talbot Neath Port Talbot SA13 1ET
Decision: Approved
Ward: Port Talbot

App No: **P2024/0135**
Proposal: Erect a conservatory and porch (retrospective).
Location: 5 Golwg Y Graig Crynant Neath Neath Port Talbot SA10 8RY
Decision: Approved
Ward: Crynant, Onllwyn & Seven Sisters

App No: **P2024/0136**

Proposal: Non-material amendment application to vary the wording of condition 12 (installation of bat boxes) to planning application P2022/0146 approved on 21/07/2023.

Location: Min Yr Afon Residential Home London Row
Cwmavon SA12 9AH

Decision: Approved

Ward: Bryn And Cwmavon

App No: **P2024/0137**

Proposal: Discharge of condition application for condition 4 (CEMP), condition 5 (gigabit), condition 6 (landscaping), condition 7 (noise management plan), condition 8 (one-way scheme), condition 10 (means of enclosure), condition 11 (refuse and recycling scheme), condition 12 (bat boxes) of application P2022/0146 determined on 21/07/2022.

Location: Min Yr Afon Residential Home London Row
Cwmavon SA12 9AH

Decision: Approved

Ward: Bryn And Cwmavon

App No: **P2024/0138**

Proposal: Non material amendment application to planning permission P2023/0720 approved 31/10/2023: New front and side boundary wall material to change from red brick to grey brick

Location: 20 The Meadows Cimla Neath Neath Port Talbot
SA11 3XF

Decision: Approved

Ward: Cimla & Peleenna

App No: **P2024/0139**

Proposal: Front gable extension

Location: 2A Waungron Glynneath Neath Neath Port Talbot
SA11 5AS

Decision: Refused

Ward: Glynneath Central & East

App No: **P2024/0145**
Proposal: Construction of new timber footbridge across existing watercourse to connect Gnoll Park with Brynau Woods
Location: Gnoll Estate Country Park Fairyland Neath SA11 3BS
Decision: Approved
Ward: Neath NorthNeath North

App No: **P2024/0147**
Proposal: Variation of condition 2 (list of approved plans) and retention of development without complying with conditions 3 (submit details of boundary treatment to first floor flat roof) and 5 (submit details of external materials) of planning permission P2022/0925 dated 28/02/2023
Location: 46 Wind Street Neath SA11 3EN
Decision: Approved
Ward: Neath North

App No: **P2024/0148**
Proposal: Lawful Development Certificate- Proposed single storey rear and side extension.
Location: 36 Maes Yr Hafod Cadoxton Neath Neath Port Talbot SA10 8AZ
Decision: Issue Certificate
Ward: Cadoxton

App No: **P2024/0150**
Proposal: Non-Material Amendment application to reduce the footprint of the barn, approved under planning application P2020/0723 determined on 01/10/2020.
Location: Crugwyllt Fach Farm Crugwyllt Fawr Access Road Margam Port Talbot Neath Port Talbot
Decision: Approved
Ward: Margam & Taibach

App No: **P2024/0151**

Proposal: Details to be agreed in association with condition 6 (Appropriate Programme of Historic Building Recording Level 2) of application P2022/1063 granted permission on 04/12/23.
Location: Former Dyffryn Lower School Talcennau Road Port Talbot SA13 1EP
Decision: Approved
Ward: Port Talbot

App No: **P2024/0153**

Proposal: Details to be agreed in association with condition 10 (Material Samples) of application P2022/0470 granted permission on 12/12/2022.

Location: Land At Baglan Way Port Talbot
Decision: Approved
Ward: Aberavon

App No: **P2024/0154**

Proposal: Front porch and side kitchen extension
Location: 39 Nobel Avenue Aberavon Port Talbot Neath Port Talbot SA12 6YN
Decision: Approved
Ward: Aberavon

App No: **P2024/0155**

Proposal: Request for Screening Opinion under Regulation 6 of the Town and Country Planning (Environment Impact Assessment) (Wales) Regulations 2017 for the Construction of a new building comprising offices, research and development and light industry (B1 use) alongside reconfiguration of the highway, parking, access, landscaping, drainage, plant, substation, sprinkler store, gas store and associated works.
Location: Land At Harbour Side Regeneration Area Port Talbot
Decision: Not EIA Development
Ward: Margam & Taibach

App No: **P2024/0157**

Proposal: Proposed two storey side extension with new outbuilding in rear garden
Location: Penyrheol 64 Alexander Road Rhyddings SA10 8EG
Decision: Approved
Ward: Bryncoch North

App No: **P2024/0162**

Proposal: The installation of a 30 metre high lattice tower supporting 6 no. antennas and 2 no. transmission dishes, radio equipment housing and ancillary development.

Location: Tata Steelworks Port Talbot South Margam Moors SA13 2NG

Decision: Approved

Ward: Margam & Taibach

App No: **P2024/0164**

Proposal: Proposed single storey side extension.

Location: Dakota House Pentwyn Baglan Road Baglan Port Talbot Neath Port Talbot

Decision: Approved

Ward: Baglan

App No: **P2024/0165**

Proposal: Change of use of ground floor from tanning salon (use class Sui Generis) to hot food takeaway including minimal internal seating (Use Class A3)

Location: 3 The Parade Neath SA11 1PU

Decision: Approved

Ward: Neath North

App No: **P2024/0166**

Proposal: Details to be agreed in association with condition 7 (demolition and construction method statement) and condition 8 (gigabit capable broadband) of planning application P2023/0369 determined 16/02/2024.

Location: Land At Heol Crwys Cwmafan Port Talbot SA12 9NT

Decision: Approved

Ward: Bryn And Cwmavon

App No: **P2024/0168**
Proposal: Lawful Development Certificate- Single storey side extension (proposed)
Location: 27 Windsor Village Aberavon Port Talbot Neath Port Talbot SA12 7EU
Decision: Issue Certificate
Ward: Aberavon

App No: **P2024/0169**
Proposal: Proposed double storey rear extension to semi-detached dwelling, the works for which would include the removal of the existing decking to create a level patio area.
Location: 46 The Greenway Llandarcy Neath Neath Port Talbot SA10 6JB
Decision: Approved
Ward: Coedffranc West

App No: **P2024/0172**
Proposal: Non-material amendment application for the proposed addition of two windows and relocation of bi-fold doors/window to spa pool extension plus glazed balustrade to Juliet balcony (in lieu of wrought iron vertical railings) and adjustments to new secondary door access to south facing elevation, and increase in extension ridge height, to planning application P2022/0682 determined on 06/10/2024.
Location: Cwrt Bychan House Cwrt Buchan Lane Margam Port Talbot Neath Port Talbot
Decision: Approved
Ward: Margam & Taibach

App No: **P2024/0177**
Proposal: Existing bank facilities (night safe, ATM, alarm box, CCTV and signage) to be removed and exterior of building made good with apertures infilled with stonework to match existing and windows re-instated to match existing.

Location: 9 The Parade Neath Neath Port Talbot SA11 1RE
Decision: Approved
Ward: Neath North

App No: **P2024/0183**
Proposal: Discharge of condition 5 (construction environmental management plan) of planning permission P2022/0956 dated 08.03.2023 (for a new cinema extension)
Location: Pontardawe Arts Centre 60 Herbert Street
Pontardawe SA8 4ED
Decision: Approved
Ward: Pontardawe

App No: **P2024/0186**
Proposal: Request for Screening Opinion under Regulation 6 of the Town and Country Planning (Environment Impact Assessment) (Wales) Regulations 2017 for the construction of a series of 120 holiday lodges, supporting infrastructure (access, parking, landscaping and drainage) and a clubhouse with a pool, food and drink hospitality and associated road.
Location: Parc Pelenna Fairyland Road Tonna Neath SA11 3QE
Decision: EIA Development
Ward: Resolven & Tonna

App No: **P2024/0190**
Proposal: Non material amendment to approved planning application P2023/0512 to remove condition 4 relating to existing parking arrangements to no.78 Leyshon Road - existing garage and parking arrangement to remain.
Location: Leyshon Road Gwaun Cae Gurwen SA18 1EN
Decision: Approved
Ward: Gwaun Cae Gurwen & Lower Brynamman

App No: **P2024/0193**
Proposal: 2 no. 'High Power' information signs, 1no. 'accessible parking' sign and 2 no. directional signs.

Location: Baglan Bay Retail Park Christchurch Road Aberavon
SA12 7BZ
Decision: Approved
Ward: Aberavon

App No: **P2024/0195**
Proposal: Demolition of existing rear extension, replacement rear
extension and outbuilding
Location: 55 Victoria Road Sandfields Port Talbot Neath Port
Talbot SA12 6QQ
Decision: Approved
Ward: Sandfields East

App No: **P2024/0217**
Proposal: Certificate of lawfulness for a proposed single storey
rear extension
Location: 5 Cwrt Yr Eos Coed Hirwaun Port Talbot Neath Port
Talbot SA13 2UQ
Decision: Issue Certificate
Ward: Margam & Taibach

App No: **P2024/0224**
Proposal: Details to be agreed in association with Condition 7
(Construction Environmental Management Plan) of
P2023/0322 granted on 12/10/23
Location: Abbey Primary School Heol Penlan Longford Neath
SA10 7LB
Decision: Approved
Ward: Dyffryn

App No: **P2024/0229**
Proposal: Certificate of lawfulness for a proposed rear
conservatory and a new roof design on the existing
single storey rear extension
Location: 7 Cobham Drive Cimla Neath Neath Port Talbot
SA11 2BP
Decision: Issue Certificate
Ward: Cimla & Pelenna

App No: **P2024/0252**
Proposal: Details to be agreed in association with condition 13
(Piling Method Statement) of application P2021/0856
granted permission on 22/12/2022.
Location: Eagle House 2 Talbot Road Port Talbot Neath Port
Talbot SA13 1DH
Decision: Approved
Ward: Port Talbot